

ONE MACHINE. ONE EXERCISE.

TOTAL UPPER-BODY WORKOUT.

VIPER

ROPE CLIMBER

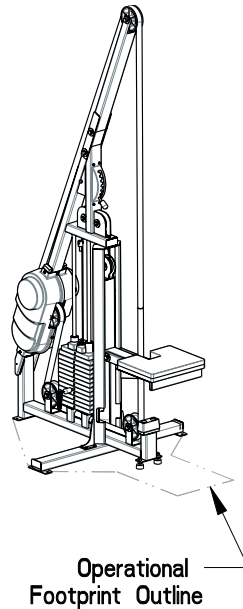
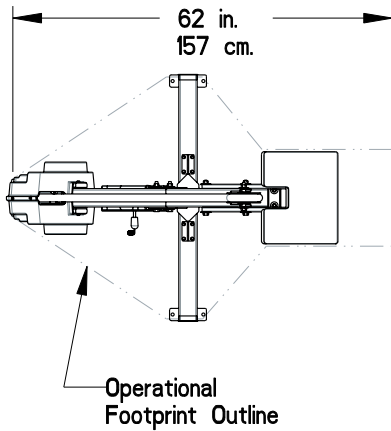

Product Specifications

Product net weight: 292 pounds (133 kg)
Shipping weight: 360 pounds (163 kg)
Shipping container size:
80 in. (203 cm.) tall
48 in. (122 cm.) wide
17 in. (43 cm.) deep
Product foot print: 16 sq. ft. (1.5 sq. meter)
Operational foot print: 19.5 sq. ft. (1.8 sq. meter)

Color Options

Frame Color: White, Silver
Seat Color: Black, Blue, Burgundy
Rope Color: Black

Any combination of these standard colors is available. Please contact us to inquire about custom designs.

