

K-101 Arm Curl

Specifications:

Dimensions:

US 42" W X 47" L X 52" H

Metric 107 cm W X 119 cm L X 132 cm H

Weight Stack:

US 85 lbs. total, 1-5 lb, 1-10 lb, 7-10 lb

Metric 39 kg total, 1-2 kg, 1-4 kg, 7-4 kg

Total Weight:

US 370 lbs.

Metric 168 kg

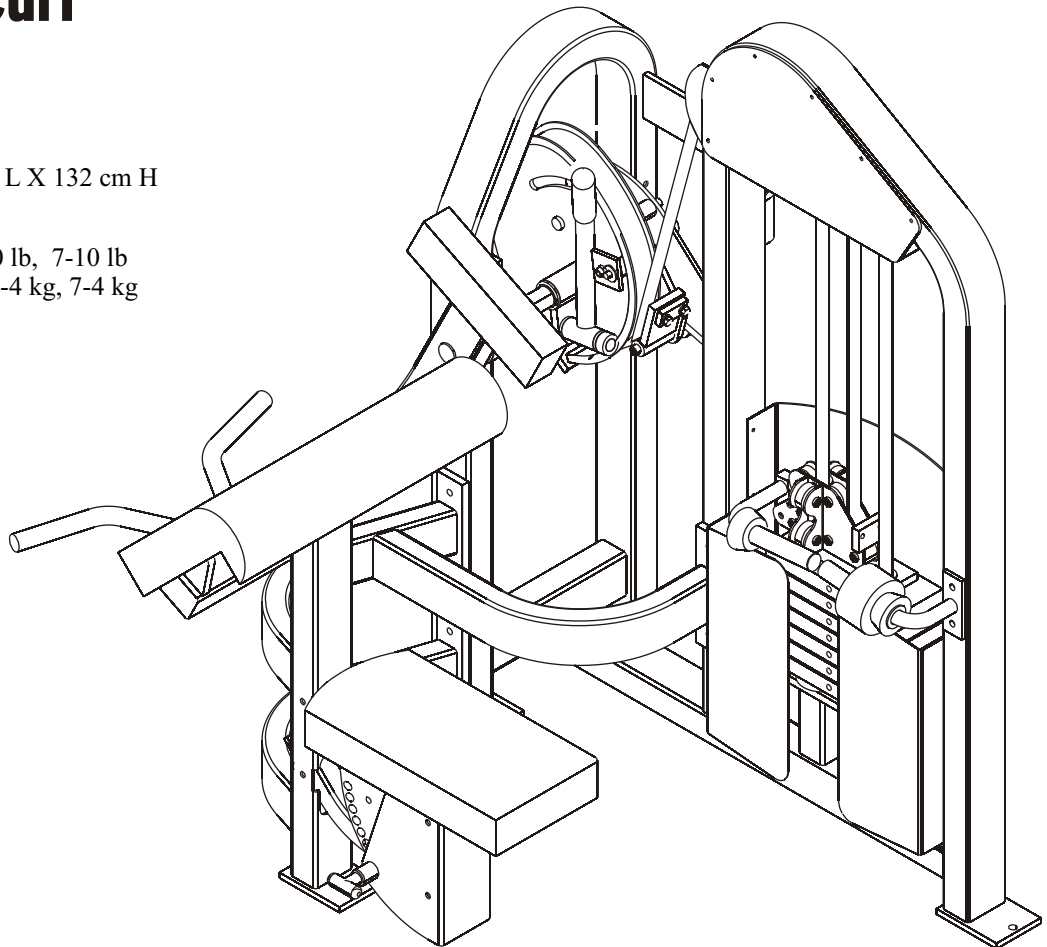

Features:

- Four bar linkage, gas-assisted seat has 8 adjustment positions to accommodate various size trainees.
- Handle design allows for wide and narrow grip; rotating grips self adjust for various size trainees.
- 45° angled arm pad allows for full range of motion and correct bio-mechanics for isolation of the biceps.
- Smart Strength technology offers 3 different cam profiles simply by adjusting the cam; resistance curves are altered to stimulate different muscle fibers.
- Add on weights in 5 lb increments allow the trainee to fine tune their resistance requirements.
- Roller bearings are used to guide the weight stack top plate creating a smoother motion and consistent stem alignment.
- Adjustable cam has been modified to create strength curves specific for youth.