

K-102 Chest Press

Specifications:

Dimensions:

US 58" W X 60" L X 52" H

Metric 147 cm W X 152 cm L X 132 cm H

Weight Stack:

US 200 lbs. total, 2-5 lb, 1-10 lb, 12-15 lb

Metric 90 kg total, 2-2 kg, 1-4 kg, 12-7 kg

Total Weight:

US 535 lbs.

Metric 242 kg

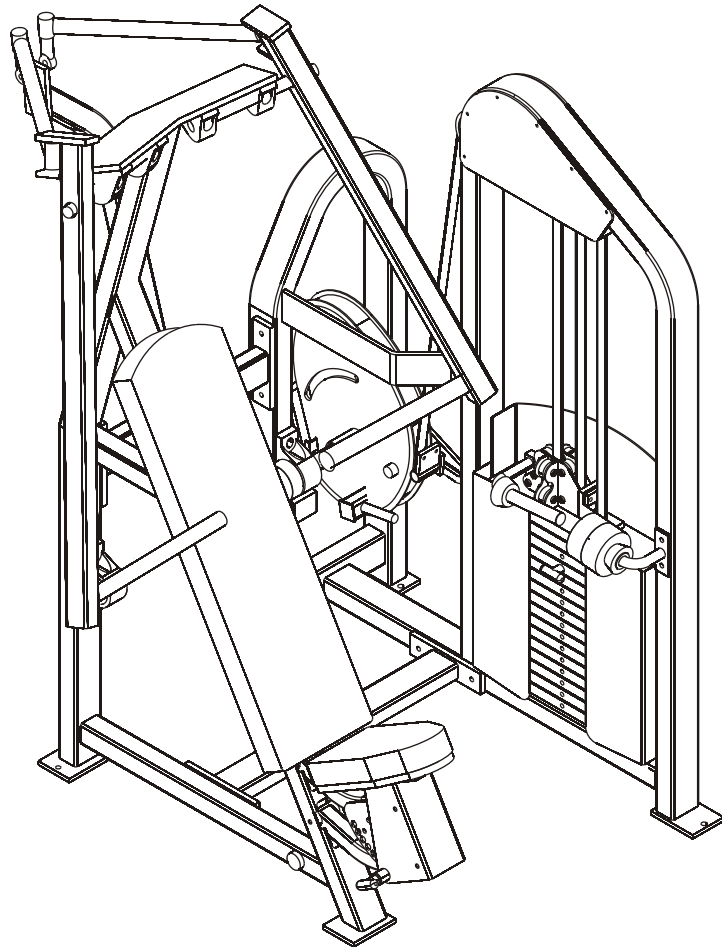

Features:

- Converging axis provides biomechanically correct exercise motion.
- Four bar linkage, gas-assisted seat has 8 adjustment positions to accommodate various size trainees.
- Handgrip design allows for wide and narrow grip positions.
- 1 1/4" handgrips for comfort.
- Optional Foot assist for desired prestretch.
- 30° angled back pad allows the head to be above the heart for comfort and ease of entry or exit.
- Smart Strength technology offers 3 different cam profiles simply by adjusting the cam; resistance curves are altered to stimulate different muscle fibers.
- Add on weights in 5 lb increments allow the trainee to fine tune their resistance requirements.
- Roller bearings are used to guide the weight stack top plate creating a smoother motion and consistent stem alignment.
- Adjustable cam has been modified to create strength curves specific for youth.