

K-110 Low Back Extension

Specifications:

Dimensions:

US 42" W X 42" L X 52" H

Metric 107 cm W X 107 cm L X 132 cm H

Weight Stack:

US 135 lbs. total, 1-5 lb, 1-10 lb, 12-10 lb

Metric 61 kg total, 1-2 kg, 1-4 kg, 12-4 kg

Total Weight:

US 410 lbs.

Metric 186 kg

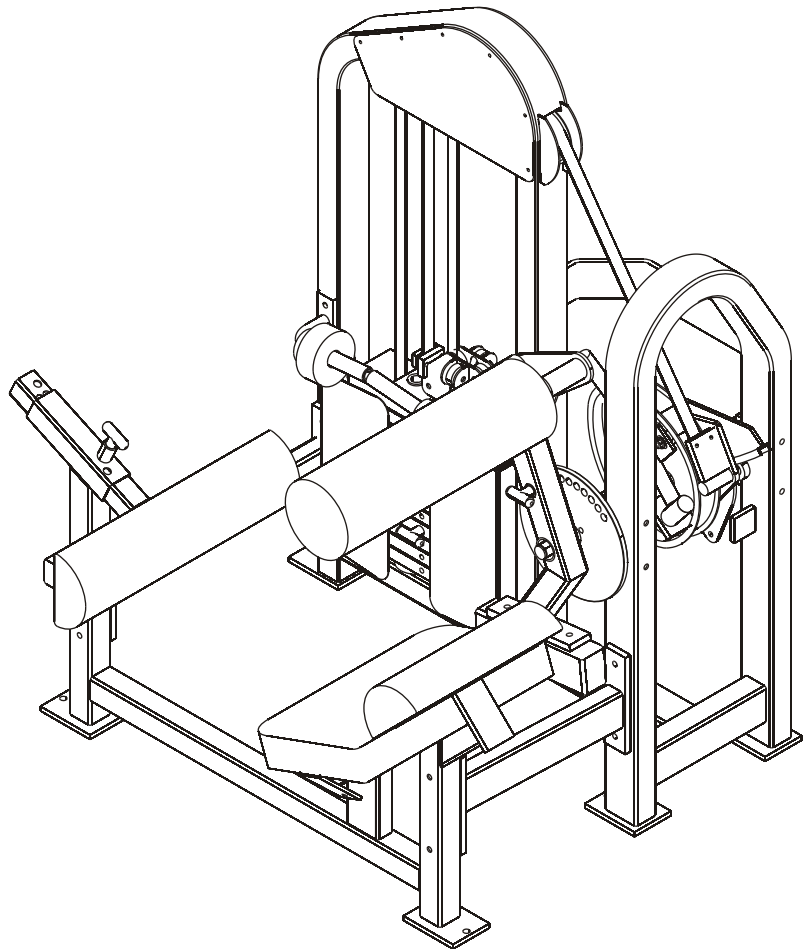

Features:

- 20° seat pad for correct biomechanical positioning.
- Built-in starting range limiter adjusts in 10° increments with 8 adjustment positions.
- Unique leg pad correctly holds user in the correct biomechanical position through the range of motion.
- Retractable and easy access seatbelt holds the trainee throughout full range of motion.
- Smart Strength technology offers 3 different cam profiles simply by adjusting the cam; resistance curves are altered to stimulate different muscle fibers.
- Add on weights in 5 lb increments allow the trainee to fine tune their resistance requirements.
- Roller bearings are used to guide the weight stack top plate creating a smoother motion and consistent stem alignment.
- Adjustable cam has been modified to create strength curves specific for youth.