

K-127 Diverging Lat Pulldown

Specifications:

Dimensions:

US 54" W X 59" L X 52" H

Metric 137 cm W X 159 cm L X 132 cm H

Weight Stack:

US 200 lbs. total, 2-5 lb, 1-10 lb, 12-15 lb

Metric 91 kg total, 2-2 kg, 1-4 kg, 12-7 kg

Total Weight:

US 530 lbs.

Metric 240 kg

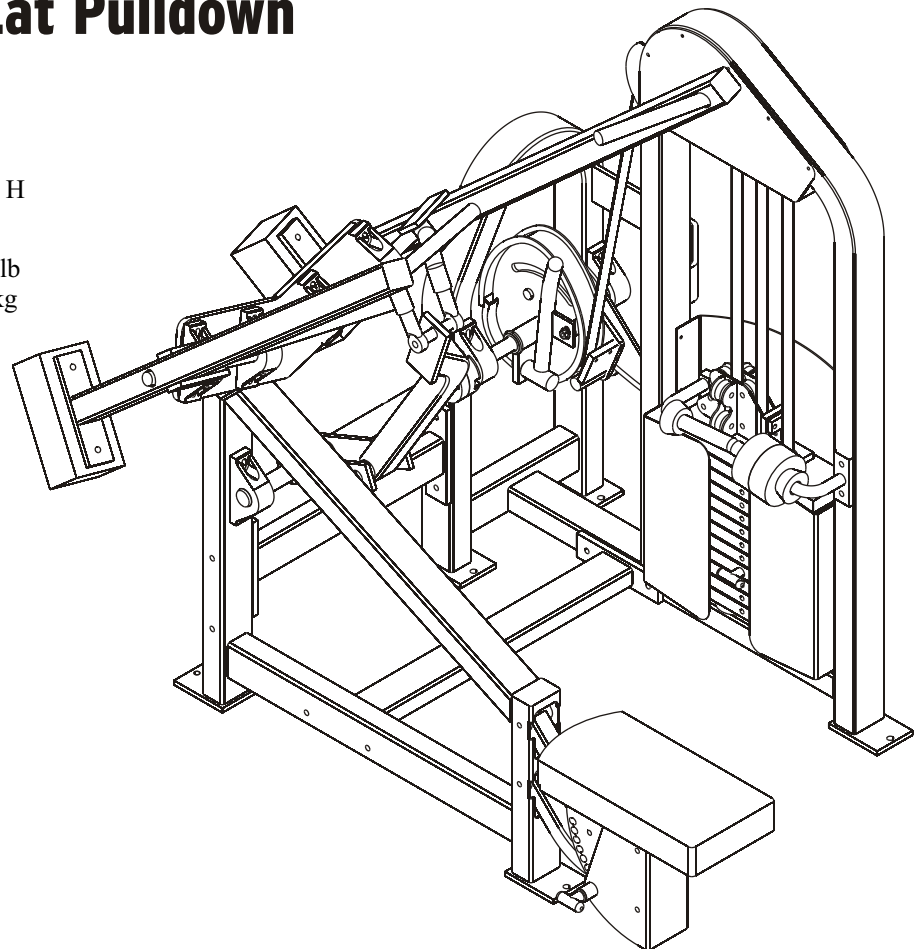

Features:

- Diverging axis provides bio-mechanically correct exercise motion.
- 1 3/8" handgrips for comfort.
- Handgrip design allows for wide and narrow grip positions.
- Smart Strength technology offers 3 different cam profiles simply by adjusting the cam; resistance curves are altered to stimulate different muscle fibers.
- Four bar linkage, gas-assisted seat adjusts to 8 positions to accommodate various size trainees and to adjust pre-stretch.
- Optional gas-assisted leg pad adjusts to 8 positions to accommodate various size trainees.
- Add on weights in 5 lb increments allow the trainee to fine tune their resistance requirements.
- Roller bearings are used to guide the weight stack top plate creating a smoother motion and consistent stem alignment.
- Adjustable cam has been modified to create strength curves specific for youth.