

K-129 Pec/Rear Delt

Specifications:

Dimensions:

US 28" W X 63" L X 63" H

Metric 71 cm W X 160 cm L X 160 cm H

Weight Stack:

US 135 lbs. total, 1-5 lb, 1-10 lb, 12-10 lb

Metric 61 kg total, 1-2 kg, 1-4 kg, 12-4 kg

Total Weight:

US 465 lbs.

Metric 211 kg

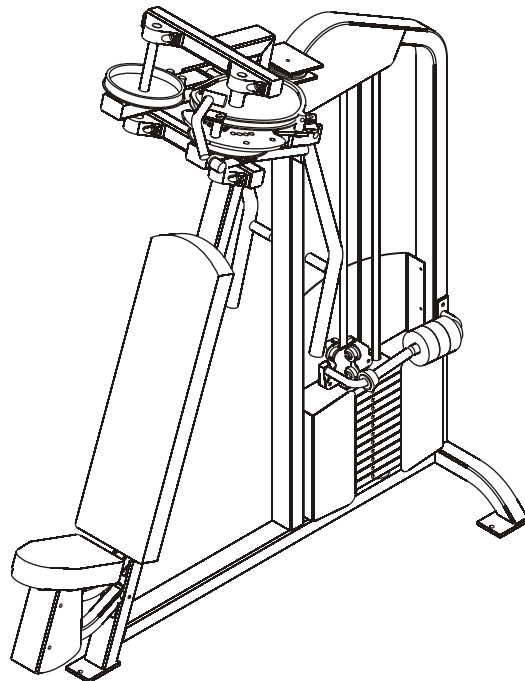

Rear Delt Fly Position

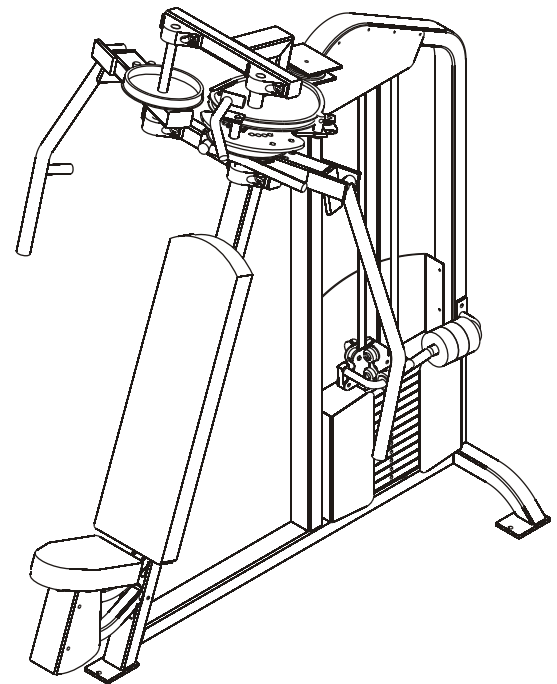

Pectoral Fly Position

Features:

- Dual unit, both pectoral fly and rear delt fly
- Arms pivot to accommodate to various size trainees.
- Four bar linkage, gas-assisted seat adjusts to 8 positions to accommodate various size trainees and to adjust pre-stretch.
- Add on weights in 5 lb increments allow the trainee to fine tune their resistance requirements.
- Smart Strength technology offers 3 different cam profiles simply by adjusting the cam; resistance curves are altered to stimulate different muscle fibers.
- Roller bearings are used to guide the weight stack top plate creating a smoother motion and consistent stem alignment.
- Adjustable cam has been modified to create strength curves specific for youth.